

產品規格 / 承認書
PRODUCT SPECIFICATION / APPROVAL SHEET

A. 一般規格 (General Specification)

項目 (Item)		規格 / 條件 (Specification / Condition)	
01	型號 (Part No.)	FD128015MB (2F5) (Sys-p: YHSFA-0049A)	
02	外型尺寸 (Outline Dimension)	80 X 80 X 15 mm	
03	額定電壓 (Rated Voltage)	DC 12.0 V	
04	操作電壓 (Operating Voltage)	DC 7.0 V ~ DC 13.2 V	
05	起動電壓 (Starting Voltage)	DC 7.0 V	
06	額定電流 (Rated Current)	0.09 A	+ 10%
07	額定功率 (Rated Power Consumption)	1.08 W	
08	轉速 (Rotational Speed)	2600 R.P.M.	± 10%
09	最大風量 (Max. Airflow)	23.7 CFM (ft3/min)	a. 額定電壓 (Rated Voltage) b. 標準 (Standard): AMCA c. 額定電流 (Rated Current)
		0.672 m3/min	
10	最大靜壓 (Max. Static Pressure)	0.113 in-H ₂ O	a. 額定電壓 (Rated Voltage) b. 無響室 (Non-Echo Chamber) c. 標準 (Standard): CNS 8753 d. 距離 (Distance): 1.0 M
		2.9 mm-H ₂ O	
11	音量位準 (Noise Level)	26.0 dB(A)	a. 額定電壓 (Rated Voltage) b. 無響室 (Non-Echo Chamber) c. 標準 (Standard): CNS 8753 d. 距離 (Distance): 1.0 M
12	壽命預估 (Life Expectancy)	80000 hrs	at 40°C a. L ₁₀ at Conf. Level 90% b. 額定電壓 (Rated Voltage)
13	極數 (No. of Pole)	4 極 (Poles)	
14	迴轉方向 (Rotational Direction)	逆時針 (Counter-Clockwise)	

B. 電氣規格 (Electrical Specification)

項目 (Item)		規格 / 條件 (Specification / Condition)	
01	扇葉鎖住保護 (Locked Rotor Protection)	○	安規條件。(Safety Condition)
		○	1. 額定電壓鎖住1秒, 自動斷電。 (Auto power off after locked at rated voltage for 1 sec.) 2. 自動斷電後, 2至6秒自動嘗試啟動。 (After auto power off, circuit attempt to restart in 2 to 6 sec.)
02	極性保護 (Polarity Protection)	○	Vcc與GND反接時, 不導通。 (Open circuit when Vcc & GND are exchanged)
		○	Vcc與GND反接時, 5秒內迴路不燒燬(Circuit won't be burned within 5 seconds when Vcc & GND are exchanged)
03	絕緣阻抗 (Insulation Resistance)	10 MΩ / 裸線與外框間測量, 500 VDC/min. (10 MΩ / Between unshielded wire and frame at 500 VDC/min)	
04	絕緣耐壓 (Dielectric Strength)	5 mA Max. / 導線與外框間測量, 500 VAC/min. (5 mA Max. / Measured b/w lead wire (+) and frame at 500 VAC/min)	

C. 主要材料/零件規格 (Main Materials / Parts Specification)

材料/零件 (Materials / Parts)		規格 (Specification)
01	塑膠材料 / 扇葉、外框、絕緣套 (Plastic Material/Blade, Housing, Bobbin)	a. UL 94V-0 b. P.B.T. + 30% GF Black
02	軸承 (Bearing)	雙滾珠軸承(Two Ball Bearing)
03	導線 (Lead Wire)- G. P.	Red (+), Black (-): UL 1007 \ 26 AWG Yellow (FG): UL 1007 \ 26 AWG
04	端子 (Connector)	N / A

D. 安規規格 (Safety Approvals)

安規(Safety)	UL	CUL	TUV	
安規編號(File No.)	E187205	E187205	R50027591	
安規承認電流 0.11 A + 10% (Approved current is 0.11 A with tolerance of 10%)				

E. 環境測試 (Environmental Specification)

項目 (Item)		規格/條件 (Specification / Condition)
01	運轉溫/溼度範圍 (Operating Temp. Range)	溫度 / Temperature : -10 °C - 70 °C
		溼度 / Humidity : 15 % - 90 % RH (Frost Eliminated)
02	保存溫/溼度範圍 (Storage Temp. Range)	溫度 / Temperature : -20 °C - 75 °C
		溼度 / Humidity : 15 % - 90 % RH (Frost Eliminated)

F. 商標 (Label Marking)

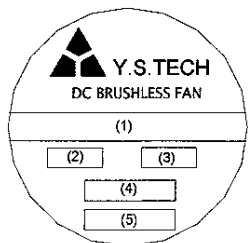

(6)
(Top Frame Side)

(1)	型號 (Model No.)
(2)	額定電壓 (Rated Voltage)
(3)	安規電流 (Safet Current)
(4)	安規 (Safety Approvals)
(5)	產地 (Location)
(6)	附碼 (Appendix Code)

G. 噪音量測條件 (Noise Measure Condition)

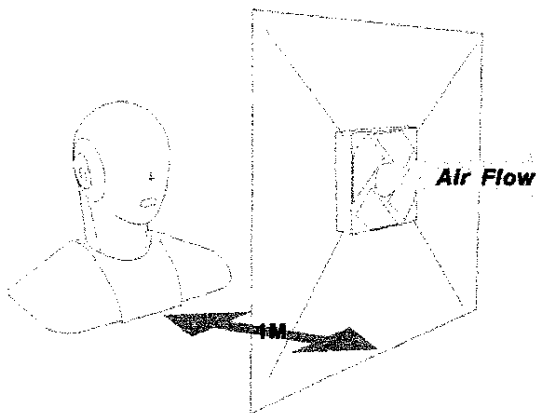

量測系統 (Measurement Systems) :
1.ANECHOIC Room Noise Measurement System.
2.Digital Head Measurement System, 16-bits version.
3.SQlab III, Mobile Multichannel Analysis System.
4.Specifications: CNS 8753, JIS 8346
5.Background Noise: < 17dB(A)

H. 外觀尺寸圖 (Outline Dimension)

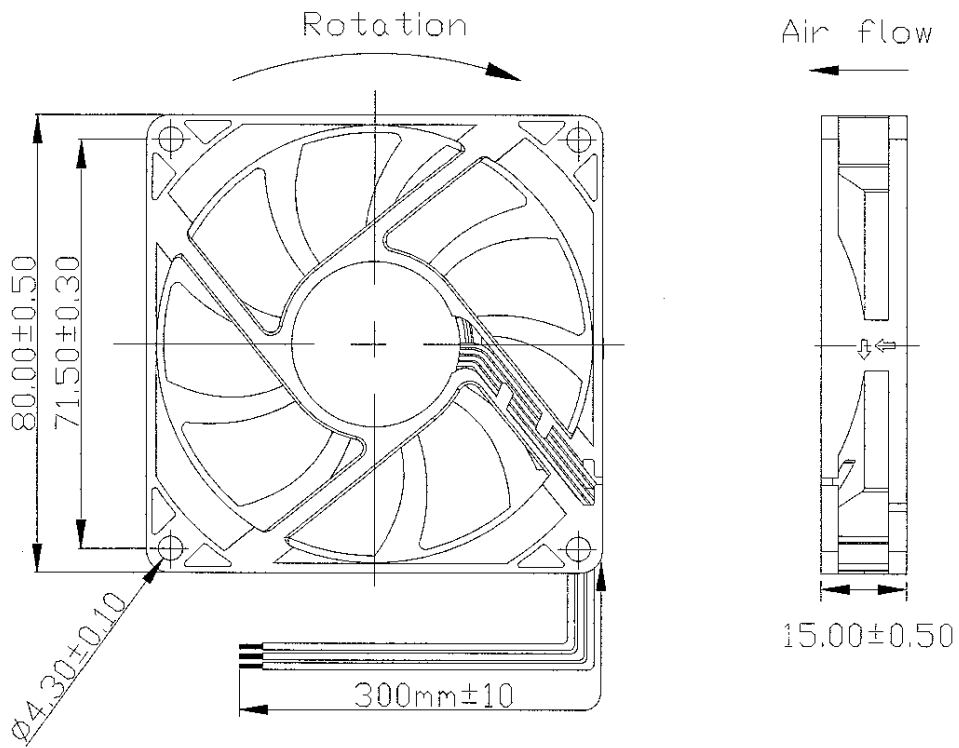

I: 訊號控制系統(Sensor Circuit System)

Speed Sensor / Tachometer (FG/F)

